

## Specifications

### TLP Pro 725T Series

#### Display

Screen type.....	TFT Active matrix color LCD display
Size.....	7" (17.8 cm), measured diagonally
Resolution.....	1024x600
Pixel/pixel pitch.....	170
Aspect ratio.....	Widescreen
Color depth.....	24 bit, 16.7 million colors
Transparency.....	8 bit
Brightness.....	420 nits (cd/m2)
Contrast.....	700:1
Backlight.....	LED
Viewing angle.....	±75° horizontal, +70°/-75° vertical
Touch screen.....	Capacitive

#### Memory

SDRAM.....	2 GB
Flash.....	8 GB

#### Communication — Ethernet interface

Ethernet control/communications port.....	1 female RJ-45 connector
Ethernet data rate.....	10/100/1000Base-T, half/full duplex with autodetect
Ethernet protocol.....	DHCP, DNS, HTTP, HTTPS, ICMP, IEEE 802.1x, SFTP, SSH, TCP/IP, UDP/IP
Default settings.....	Link speed and duplex level: autodetected IP address = 192.168.254.251 Subnet mask = 255.255.255.0 Default gateway = 0.0.0.0 DHCP = off DNS = 127.0.0.1

#### Software

Configuration software.....	Global Configurator Plus and Professional, GUI Designer
Programming software.....	ControlScript Programming
Control apps.....	Extron Control
Resource management software..	GlobalViewer Enterprise
Utilities.....	Toolbelt, Embedded web page

#### Communication — touchpanel

Motion sensor.....	On/off
Light sensor.....	On/off

#### Control — USB

Number/signal type.....	1 high-speed USB 2.0 device
Connectors.....	1 USB type A connector
USB standards.....	USB 2.0, USB 1.1, USB 1.0 compatible
USB data rates.....	Low speed (1.5 Mbps), full speed (12 Mbps)

# Specifications • TLP Pro 725T Series (Continued)

## Audio output

Speaker output.....	1 mono, 86 dB SPL, 0.1 watt, 0.1 m, half space
Frequency response .....	750 Hz to 20 kHz, ±5 dB
Playback format(s)	
Container format.....	WAV (Microsoft RIFF)
Encoding .....	LPCM (uncompressed)
Bit depth .....	Unsigned 8-bit Signed 16-bit Signed 24-bit Signed 32-bit
Sampling rate .....	up to 192 kHz
Audio channels .....	mono or stereo

## General

Power supply .....	Not included
Power input requirements .....	Power over Ethernet (PoE 802.3af, class 3)
Power consumption — Power injector (XTP PI 100)	
Device .....	8.2 watts
Device and power injector .....	10.6 watts
Temperature/humidity .....	Storage: -4 to +158 °F (-20 to +70 °C) / 5% to 90%, noncondensing Operating: -4 to +158 °F (-20 to +70 °C) / 20% to 90%, noncondensing
Cooling.....	Convection, vents on back
Thermal dissipation — Power injector (XTP PI 100)	
Device .....	23.1 BTU/hr
Device and power injector .....	31.3 BTU/hr
Mounting .....	Set on tabletop
Enclosure type .....	Plastic

# Specifications • TLP Pro 725T Series (Continued)

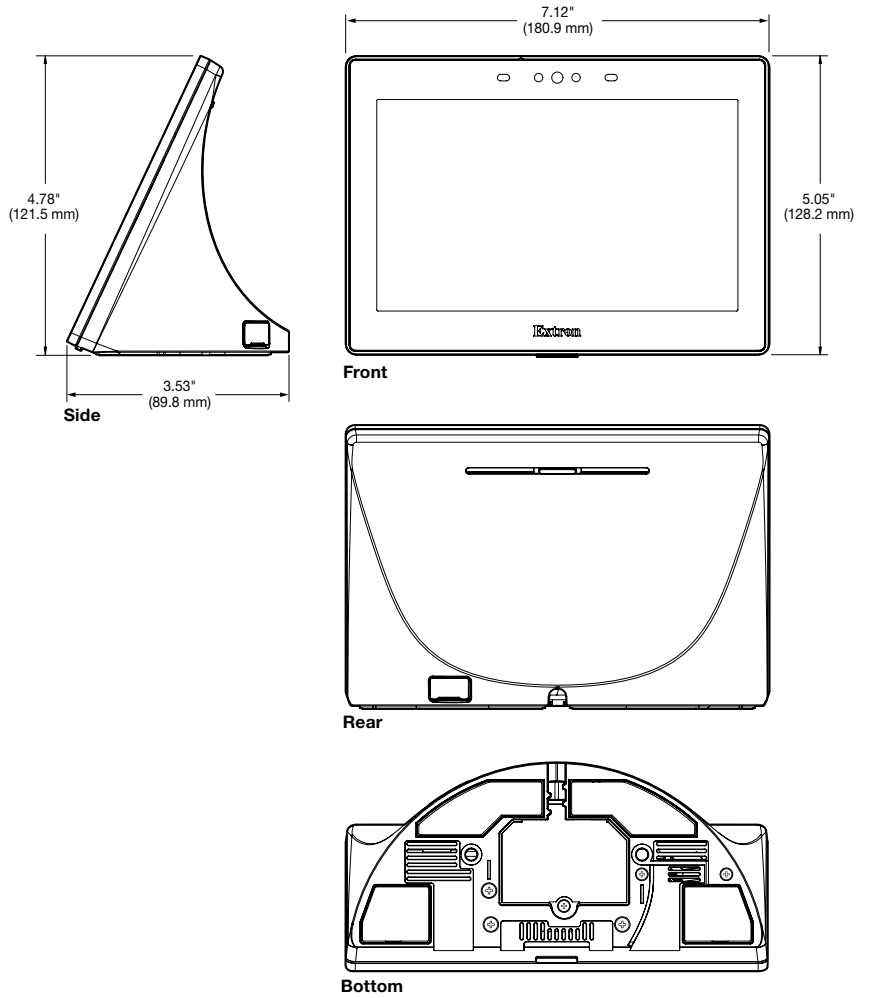

Enclosure dimensions.....	4.78" H* x 7.12" W x 3.53" D (122 mm H* x 181 mm W x 90 mm D)
Product weight .....	1.75 lbs (0.79 kg)
Regulatory compliance .....	BIS, CE, C-Tick, c-UL, FCC Class B, ICES, RoHS, UL, VCCI, and WEEE
Product warranty.....	3 years parts and labor; touchpanel display and overlay components are covered for 1 year

**NOTES:**

- All nominal levels are at ±10%.
- Specifications are subject to change without notice.
- Shipping dimensions and weights are available at [www.extron.com](http://www.extron.com).

6111-D5